

METAL ROOF: THREE COURSE FABRIC REINFORCED

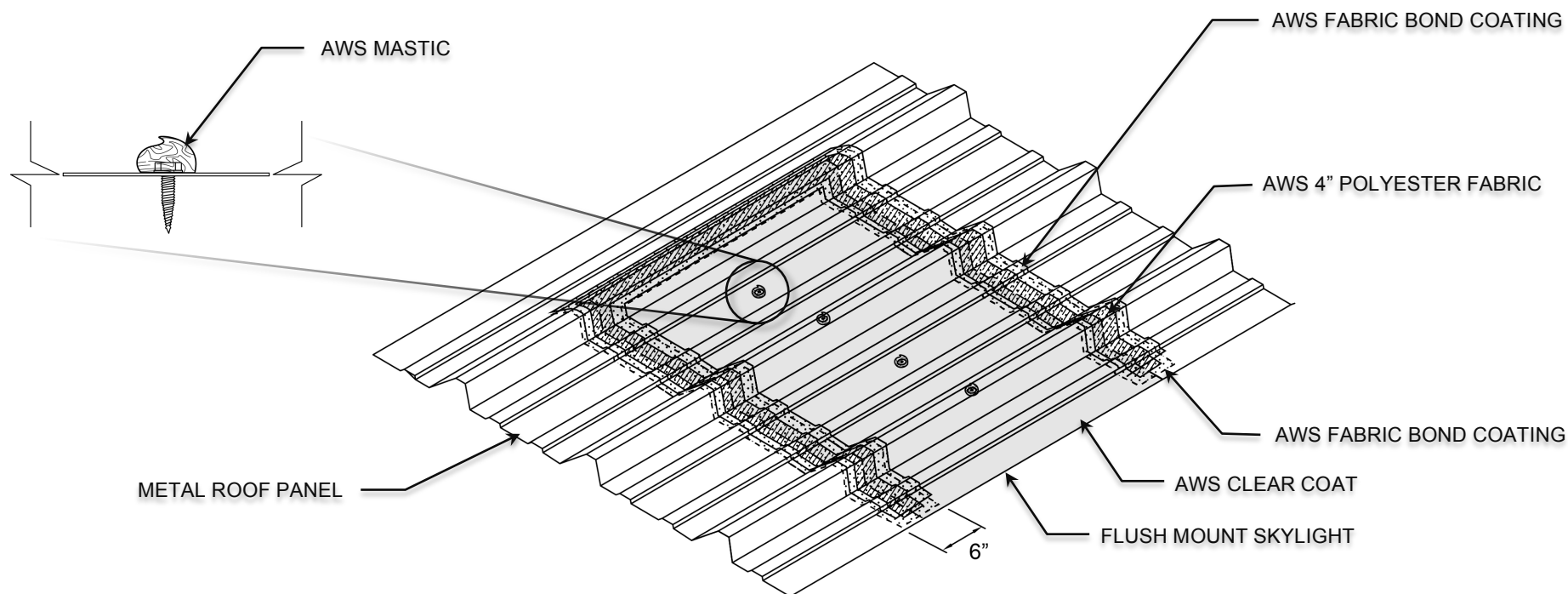

1. Use stitch screws to close excessive gaps.
 2. Apply AWS clear coat at a rate of approximately 16 wet mils to surface of skylight.
- SPECIAL NOTE: Never coat over skylight with any coating other than those that are clear or opaque.
3. Apply a 6" wide layer of AWS fabric bond coating centered on and parallel to both the horizontal and vertical flush - skylight seams on existing metal roof panel.
 4. Embed 4" AWS polyester fabric into wet fabric bond coating.
 5. Apply a 6" wide layer of AWS fabric bond coating centered on and parallel to both the horizontal and vertical flush - skylight seams on existing metal roof panel encapsulating the polyester fabric. (Pay special attention to fabric details at the ribs so as to not catch water.)
 6. Use AWS mastic to encapsulate any exposed screws used to secure the skylight to the roof.

NOTE: Contact American WeatherStar with any questions.



800.771.6643

AMERICANWEATHERSTAR.COM

SKYLIGHT – FLUSH MOUNT

See specific application guideline for suitable AWS fabric bond coating.

NOTE: This detail is provided to show a generally recommended procedure for dealing with the condition shown. It will not and cannot provide a specific solution for every condition likely to be encountered in field application. Where field conditions differ, the use of applicable portions of the detail shown or its adaptation by an experienced and conscientious applicator should result in a quality project.

LEGEND



FABRIC BOND COATING



POLYESTER FABRIC

REVISION DATE: 12/28/2015

SCALE: NTS